

1. Gasification

Dr. Samy Sadaka, P.E., P.Eng.

Associate Scientist, Center for Sustainable Environmental Technologies

Adjunct Assistant Professor, Department of Agricultural and Biosystems Engineering

Iowa State University

1521 West F. Ave.

Nevada, IA 50201

1.1. Introduction

Gasification is the controlled partial oxidation of a carbonaceous material, and it is achieved by supplying less oxygen than the stoichiometric requirement for complete combustion. A central process between combustion (thermal degradation with excess oxygen) and pyrolysis (thermal degradation in the absence of oxygen), it proceeds at temperatures ranging between 600 and 1500 °C. Depending upon the process type and operating conditions, low- or medium-value producer gas (which is a combination of combustible and non-combustible gases) is created.

Gasification technology has been widely used to produce commercial fuels and chemicals. Current developments in the chemical manufacturing and petroleum refinery industries show that use of gasification facilities to produce synthesis gas will continue to rise. A striking feature of the technology is its ability to produce a reliable, high-quality syngas product that can be used for energy production or as a building block for chemical manufacturing processes.

In addition, it includes the ability to house a wide variety of gaseous, liquid, and solid feedstocks. Conventional fuels such as coal and oil, as well as low- or negative-value materials and wastes such as petroleum coke, heavy refinery residuals, secondary oil-bearing refinery materials, municipal sewage sludge, and chlorinated hydrocarbon byproducts have all been used successfully in gasification operations. Biomass and crop residues also have been gasified successfully. Gasification of these materials has many potential benefits over conventional options such as combustion or disposal by incineration.

1.2. Gasification Process

During gasification of biomass, the material is heated to a high temperature, which causes a series of physical and chemical changes that result in the evolution of volatile products and

carbonaceous solid residues. The amount of volatiles produced and their compositions depend on the reactor temperature, type, and characteristics of fuel material. It is generally accepted that the char gasification stage is the rate limiting in the gasification of biomass because the devolatilization stage is very fast. The composition of the final product gas is also dependent on the degree of equilibrium achieved by various gas-phase reactions, particularly the water-gas shift reaction. In the absence of a catalyst, gasification of char with reactive gases such as O₂, H₂O and CO₂ occurs at higher temperatures (700°C to 1000°C) according to the following reaction:

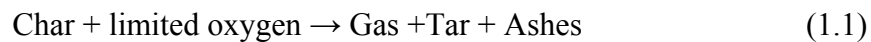

When char is gasified in the presence of steam, the gas produced is composed mainly of CO₂, CO, H₂ and CH₄. Steam may be added from an external source or from the dehydration reactions of crop residues. In reactors operating at low temperatures, low heating rates and very high pressure, secondary reactions are very important because of long residence times (of the volatile products in the reaction zone). On the other hand, at low pressure, high temperature, and high heating rates, most of the volatile products escape instantaneously from the fuel particles during pyrolysis, hence reducing the chances of a solid char-gas interaction. In fluidized bed gasifiers, the latter prevails but because of the mixing nature of the bed, secondary reactions in the gas-solid and gas-gas phases take place.

Thermal decomposition of woody products starts at temperatures as low as 160°C when water distillate, known as "pyroligneous acid," is evolved. However, because the major product of biomass below 600°C is char, crop residue gasification processes are usually designed to operate at temperatures above this point. Thus, higher temperatures are required to attain appreciable rates and levels of char conversion to a gaseous product, which is the primary objective of biomass gasification. The biomass gasification process occurs in four interrelated stages: 1) drying of the feedstock; 2) pyrolysis to produce volatile matter and char; 3) gasification of in situ formed char with reactive gases such as CO₂, H₂O, H₂ and O₂; and 4) secondary reactions of primary gases and tars.

The gasification process uses an agent, either air, oxygen, hydrogen or steam (see Figure 1.1.), to convert carbonaceous materials into gaseous products.

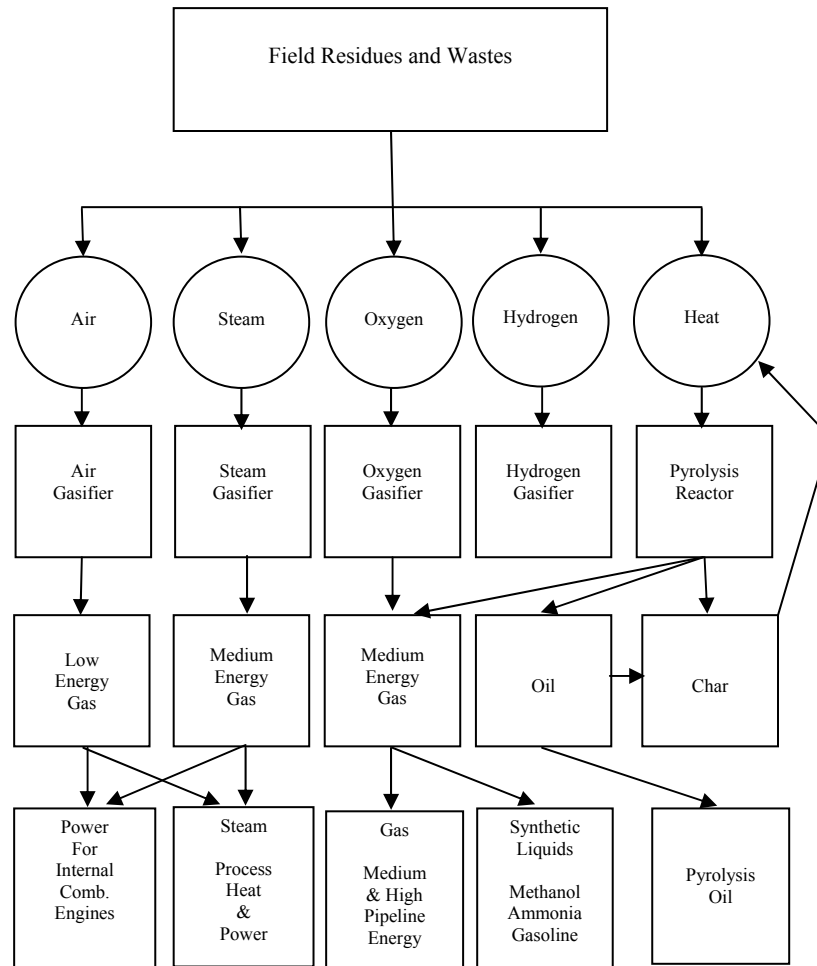

Figure 1.1. Gasification processes and their products.

1.2.1. Air gasification

The simplest gasification process uses air as a gasifying agent. Excess char formed by the pyrolysis process within the gasifier is burned with a limited supply of air (usually at an equivalence ratio of 0.25). The product is a low-energy gas containing primarily hydrogen and carbon monoxide diluted with the nitrogen from the air. The heating value of the produced gas is in the 3.5 - 7.8 MJ/Nm³ range, which makes it suitable for boiler and engine applications but not for uses that require its transportation through pipelines.

Due to its simplicity, air gasification technology is being studied by many researchers for various types of biomass. Because air is the gasifying agent, the reactor temperature is dependent

on the air flow rate and biomass feed rate. Very low inlet air to the system results in very low bed temperature, which produces lower gas, and higher tar yields.

Groves et al. (1979) studied fluidized bed air partial oxidation of cotton gin trash over the temperatures range of 922 and 1144 K in a 0.3 m I. D reactor. The off-gas heating value and energy recovery increased from 3.4 to 4.3 MJ/m³ and from 27 to 53%, respectively. Lian and Findley (1982) studied the air gasification of oak sawdust and found that the tar and char yields decreased linearly by temperature from 6% of the dry wood weight at 923 K to 0.5% at 1073 K. Researchers tested the effect of air-flow rate on the performance of the gasifier and concluded that the total carbon-to-nitrogen ratio in the dry gas gave the best correlation with the concentrations of carbon, hydrogen and the higher heating value. Walawender and Fan (1978) studied the air gasification of feedlot manure and found that gas yield, heating value, and energy recovery increased by 131%, 77% and 244%, respectively, when the temperature increased from 900 to 1100 K. Ergudenler (1993) studied the effect of air flow rate on the gas quality and quantity during air gasification of wheat straw in a fluidized bed gasifier. The results showed that at equivalence ratio of 0.25, the mole fraction of the combustible component achieved their maximum.

Cao et al. (2005) demonstrated a fluidized bed air gasification system using sawdust. They combined two individual regions of pyrolysis, gasification, and combustion of biomass in one reactor. The primary air stream and the biomass feedstock were introduced into the gasifier from the bottom and the top, respectively. Secondary air was injected into the upper region of the reactor to maintain elevated temperature. The study indicated that under optimum operating conditions, a fuel gas could be produced at a rate of about 3.0 Nm³/kg biomass and heating value of about 5.0 MJ/Nm³. The concentration of hydrogen, carbon monoxide and methane in the fuel gas produced were 9.27%, 9.25% and 4.21%, respectively.

1.2.2. Steam gasification

Unlike air gasification, steam gasification requires an external heat source if steam is used as a sole gasifying agent. Using a mixture of steam and air as a gasifying agent is not uncommon technology and has, in fact, been studied by several researchers. Oxygen in the air will help to provide the required energy due to the exothermic nature of burning biomass. The elevated temperature will help in the devolatilization process of biomass to produce various

gases. Steam will react with carbon monoxide to produce hydrogen and carbon dioxide. The principle gas-phase reaction in the steam gasification system is the water gas-shift reaction:



Compared to air gasification, steam gasification produces a higher energy content producer gas. Boateng et al. (1992) determined the effects of reactor temperature and steam to biomass ratio on producer gas composition, heating value and energy recovery. The produced gas, which is rich in hydrogen, had been found to have a heating value ranging from 11.1 MJ/m³ at temperature of 700°C to 12.1 MJ/m³ at temperature of 800°C. Energy recovery varied from 35-59% within the same temperature range. Hoveland et al. (1982) studied corn grain-dust gasification in a 0.05 m I.D. fluidized bed gasifier using steam as a fluidizing agent and a mixture of sand and limestone as the bed material. The produced gas yield increased from 0.13 m³/kg at 867 K to 0.73 m³/kg at 1033K. The gas heating value increased from 9.4 to 11.5 MJ/m³ at the same temperature range.

Walwender et al. (1981) gasified alpha cellulose in a bench-scale fluidized bed reactor using steam over a temperature range of 873-1073K. The major components of the produced gas were H₂, CO₂, CO, and CH₄ and the volumetric gas yield was 0.5-1.4 m³/kg. The average gas higher heating value was 11.8 MJ/m³. The energy recovery as well as carbon conversion were ranged from 32-90%. Walwender et al. (1982) gasified straw with steam in a 0.23 m diameter fluidized bed reactor over a temperature range of 552-757°C. The fraction of feed converted to gas ranged from 32% at 552°C to 73 % at 757°C. The heating value of the gas exhibited a parabolic temperature variation with a maximum value of 16.3 MJ/m³ obtained at 672°C. There was continuous external energy input to the system, which resulted in higher than expected heating values. According to Slapak et al. (2000), steam gasification is one possibility for recycling waste in a bubbling fluidized bed reactor. The main product is syngas, employable for energy recovery. The produced syngas has a heating value of 8.6 MJ/Nm³. Mermoud et al. (2005) studied charcoal steam gasification of beech charcoal spheres of different diameters (10-30 mm) at different temperatures (830-1030°C). Their results show a very slow reaction at 830°C. A difference in gasification rate as high 6.5 to 1 was observed between temperatures at 1030 and 830°C. Experiments carried out with mixtures of H₂O/N₂ at 10%, 20%, and 40% mol

of steam confirmed that oxidant partial pressure influences gasification. A gasification rate of 1.9 was obtained for H₂O partial pressure varying from 0.4 to 0.1 atm.

The gasification of rice husk was studied by Chen and Day (1982) over a temperature range of 873-973K. They used an electrically heated 0.05 m I. D. fluidized bed reactor. The bed consisted of fused alumina sand; the fluidizing medium was super-heated steam. The gas yield increased from 0.38 to 0.55 m³/kg and the heating value varied from 16.8 to 18.5 MJ/m³. Over this temperature range, H₂, CH₄, CO, and CO₂ concentrations in the produced gas varied from 3.6-13.1%, from 14.4-13.5%, from 52.2-51.1% and from 23-14.6%, respectively. The balance of the product gas was comprised of higher hydrocarbons including ethane, ethylene, and propylene. Corella et al. (1989) reported on steam gasification of four different crop residues (wood chips, thistle, saw-dust and straw) in a 0.15 m I.D. fluidized bed gasifier. They determined the gas, char, and tar yield at temperatures between 650-780°C for each type of crop residue. Straw and sawdust exhibited higher gas and lower tar yields compared to wood chips and thistle.

1.2.3. Oxygen gasification

If the amount of nitrogen supplied to the gasification process is limited, the product gas will not contain nitrogen and thus, have medium energy (approximately 12-21 MJ/Nm³). Such a gas can be economically distributed in pipeline network systems and therefore, be conveniently used for process heat or possibly as synthesis gas to produce chemical and fuels. In this case, an oxygen plant or a nearby source of oxygen is required, which may elevate the capital cost necessary for the plant installation.

Bailie (1979) reported a relationship between the heating value of a gas and oxygen concentrations in the fluidizing gas. At oxygen concentration of 20% and 100% the heating values of the produced gas were 6 and 11.2 MJ/Nm³, respectively. When the oxygen concentration in the fluidizing gas was increased from 20% to 100%, the mole fractions of methane, hydrogen, and carbon monoxide increased from 4 to 6%, from 13 to 19% and from 25 to 55%, respectively. Tillman (1987) gasified municipal solid waste in an oxygen gasifier. The feedstock (shredded and magnetically sorted) was fed into the top of the gasifier and the oxygen was fed at the bottom. Pyrolytic char was combusted with the oxygen at the bottom of the gasifier providing enough thermal energy to produce temperatures in the range of 1593-1704°C and to produce a molten slag from all noncombustible materials. The maximum mole fraction of

the produced gas for CO, H₂, CO₂ and CH₄ recorded were 44%, 31%, 13% and 4%, respectively. The maximum heating value was 10.6 MJ/Nm³. Watkinson et al. (1987) studied the effect of an oxygen-steam mixture on carbon conversion and gas heating value during the gasification of coal using a spouted bed. By increasing the oxygen to the carbon fed ratio from 0.5 to 1.1 kg/kg, the heating value of the produced gas per unit weight of feedstock increased sharply from 5 MJ/kg to 16 MJ/kg.

1.2.4. Hydrogen gasification

Through this route of gasification, the fuel feedstock is converted to gaseous fuels in the presence of hydrogen under high pressures. With this process, it is critical that stringent reaction conditions are maintained since the majority of the products are normally in the gaseous phase. This process is unfavorable because of the degree of control necessary as well as the fact that hydrogen must be readily available.

Weil et al. (1978) used preheated hydrogen mixed with peat at the entrance of fluidized bed gasifier. The reactor was operated as an entrained flow reactor in an isothermal or a constant heat-up mode. Increasing the temperature from 426°C to 760°C increased carbon monoxide and hydrocarbon gases from 8% to 18% and 41% to 63%, respectively.

1.3. Mechanism of Gasification

In gasifiers, as air is passed through the fuel bed, fairly discrete drying, pyrolysis, gasification and oxidation zones develop along the reactor. The location of these zones in the gasifier depends on the relative movement of the fuel and air. These zones are mainly differentiated by the variety of reactions or processes occurring and the temperature regimes at that point. The depth and relative importance of each zone depend on the chemical composition of the feedstock, its moisture content and particle size, the mass flow rate of the gasifying agent, and the temperature.

1.3.1. Drying zone

The drying zone receives its energy through heat transfer from other zones. The rate of drying depends upon the temperature, velocity, and moisture content of the drying gas, as well as the external surface area of the feed material, the internal diffusivity of moisture and the nature

of bonding of moisture to that material, and the radioactive heat transfer. As the fuels enter the drying zone, their internal temperature is increased to 100-150°C. Low density materials change dimensions slightly due to shrinkage and compression whereas negligible size changes are experienced by feedstock with high density. No chemical reactions take place in this zone.

1.3.2. Devolatilization zone

Heat transfer from the adjacent hot reduction zone causes devolatilization of the feed material. Temperature in the devolatilization zone increases rapidly due to the large temperature difference between the relatively cold feed material and hot gases. The rate of temperature rise is controlled by heat transfer. As feed material pass through this zone, rapid charring and reduction in volume transpire, causing considerable variation in the structure as well as the physical and thermal properties of the material. The products from the devolatilization zone are gases, liquid (tars and oil), and char. The production of liquids should be controlled in gasifiers in which their production is undesirable. The amounts of each of these products vary depending on the zone temperature, rate of heating, structure, and composition and size of catalysts.

1.3.3. Oxidation zone

In the oxidation zone, physical and chemical changes are inhibited as the oxygen carrier, which is mostly air, is introduced into the fuel bed material. The oxygen burns a portion of the carbon in the fuel material until practically all free carbon is exhausted. Oxygen, however, penetrates the material surface to a small extent because it more readily reacts at the surface with the formed carbon monoxide and hydrogen gases. When air is used as a gasifying medium, its oxygen content decreases from 21 to 0%, while the carbon dioxide percentage increases proportionally. The oxidation zone has the highest temperature due to the exothermic nature of the reactions.

1.3.4. Ash cooling zone

In the ash cooling zone, the reminder particles start to cool down faster than particles temperature in other zones. The ash cooling zone formed in fixed bed gasifiers protects the grate from intense heat and distributes the air over the bed. Practically no chemical reaction takes place here, although in some fixed bed designs, this zone acts as a filter for the resulting

producer gas. However, this zone preheats the incoming air stream in some designs.

1.4. Gasification Reactors

The gasification process uses several reactors, which can be classified according to the relative movement of the fuel and the gasifying medium as either fixed beds (updraft, downdraft and crossdraft) or fluidized beds (bubbling, circulating, spouted and swirling).

1.4.1. Fixed Bed Gasifiers

Fixed bed reactors are those in which solids move either countercurrent or concurrent to the flow of a gas as reaction takes place, and the solids are converted to gases. Fixed beds are particularly suited to solid fuel contacting operations that require close temperature control (especially if the temperature is variable along the flow path), carryover of particles away from the reaction zone, simple operation and minimum erosion of the body of the reactor.

1.4.1.1 Updraft Gasifier

Figure (1.2) illustrates that the flow of the fuel and gases are countercurrent to each other in the updraft gasifier. This is the earliest and simplest type of gasifier reactor known. The high temperature oxidation zone is located at the bottom of the gasifier where part of the fuel is burned. The gasifying agent is injected at the bottom of the reactor and ascends from the bottom to the top while the feedstock is introduced at the top of the reactor and descends from the top to the bottom. The fuel descends through three zones (drying, pyrolysis and oxidation) of progressively increasing temperatures. Temperatures in the oxidation zone can exceed 1500°C. The heat dispersed from the oxidation zone and the gasification zone above it is transferred by forced convection and radiation upwards to the pyrolysis and drying zones, thus providing the heat required for drying, pyrolysis and endothermic char gasification processes. The oxidation zone lies at the bottom of the gasifier and the combustion gas passes through this zone reacting with the char, thereby releasing the required process heat. The produced gases, tar and other volatiles disperse at the top while ashes are removed at the bottom of the reactor. Part of the fuel is burned in the oxidation zone.

The gas produced by an updraft gasifier usually exits at low temperatures (approximately 400 °C) and thus is rich in hydrocarbons and has high tar content. The tar contains as much as

30% of the energy in the original crop biomass. The high tar content is not a major problem if the producer gas is used for direct heat applications. However, it requires thorough cleaning for internal combustion engine applications. The product gas from an updraft gasifier contains more CO, but less CH₄, ethane and acetylene than gas from other gasifiers. Updraft gasification of biomass using particulate fuels has been used widely in agricultural and industrial applications. The use of an endothermic agent (usually steam) has been the traditional approach for controlling the oxidation zone temperature of updraft gasifiers. Exhaust gas re-circulation is another approach to control the temperature of an updraft gasifier.

Updraft gasifiers have several advantages, including simple design and construction, low gas exit temperature, high charcoal burnout and high thermal efficiency. However, slagging can be very severe in updraft gasifiers, especially with high ash-content fuels like cereal straws and corn cobs. Other disadvantages include high tar content and unsuitability for use with fluffy, low density feedstock.

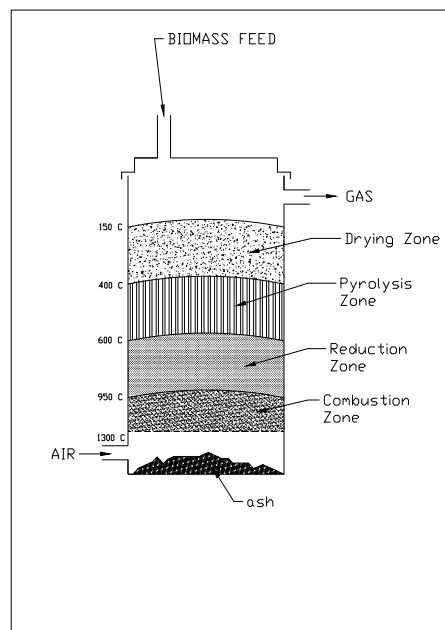

Figure 1.2. Updraft gasifier

1.4.1.2. Downdraft Gasifier

Reaction zones in a downdraft gasifier are similar to those in the updraft unit, except the

locations of the oxidation and reduction zones are interchanged. The most important difference is that the pyrolysis products in the downdraft type (Figure 1.3) are allowed to pass through the high temperature oxidation zone. Hence, they undergo further decomposition. Also, the moisture vaporized from the biomass enters the gasification zone and serves as a gasifying agent. The final product gases, which leave the gasifier from the bottom at a fairly high temperature (700°C), contain substantially less tar than the updraft gasifiers. In a downdraft gasifier, feedstock is introduced at the top and the gasifying agent is introduced through a set of nozzles located on the sides of the reactor.

The benefit of the downdraft gasifier lies in its ability to produce gas with low oil and tar contents, which means less cleaning before use in internal combustion engines. The gas can, therefore, be used with minimal filtering as a fuel for spark ignition and diesel engines. However, due to slag and clinker formation problems, this type of gasifier has been found unsuitable for fuels with high ash content and low ash fusion temperatures, such as crop residues. A major drawback is its inability to handle fine and fluffy (low density) crop residues materials.

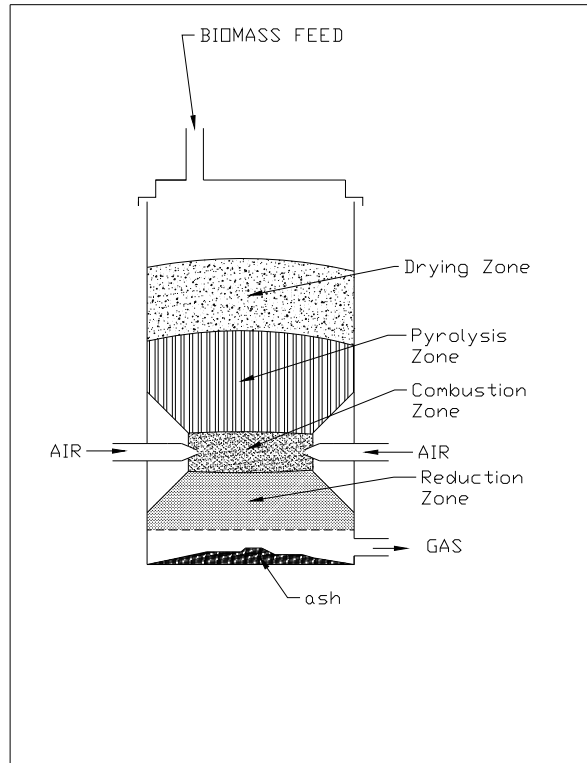

Figure 1.3. Downdraft gasifier

1.4.1.3 Cross-draft Gasifier

Cross-draft gasifiers exhibit many operating characteristics of the down draft units. Air or air/steam mixtures are introduced in the side of the gasifier near the bottom while the product gas is drawn off on the opposite side. Normally an inlet nozzle is used to bring the air into the center of the combustion zone as shown in Figure 1.4. The velocity of the air as it enters the combustion zone is considerably higher in this design, which creates a hot combustion zone. The combustion (oxidation) and reduction zones are both concentrated to a small volume around the sides of the unit. Cross-draft gasifiers respond rapidly to load changes. They are normally simpler to construct and more suitable for running engines than the other types of fixed bed gasifiers. However, they are sensitive to changes in biomass composition and moisture content.

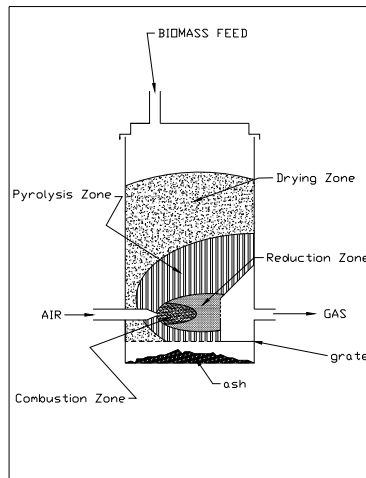

Figure 1.4. Cross-draft gasifier

1.4.2. Fluidized Beds

Unlike fixed bed reactors, models with a fluidized bed have no distinct reaction zones—drying, pyrolysis and gasification occur simultaneously in the reactor—as the reactor is mixed and, thus, closed to isothermal. Fluidized bed reactors can be classified by configuration and the velocity of the gasifying agent, e.g., bubbling, circulating, spouted, and swirling fluidized beds.

1.4.2.1. Bubbling fluidized bed

In bubbling fluidized beds, granular material is fed into a vessel through which an upward flow of gas passes at a flow rate where the pressure drop across the particles is sufficient to support their weight (incipient fluidization). In bubbling fluidization (at relatively low fluidization velocity just above the minimum fluidization velocity), the gas in excess of that needed for minimum fluidization passes through the bed in the form of bubbles. Bubbles grow by coalescence as they rise in the bed. At the bed surface, the bubbles burst causing a shower of bed solids to leave the bed surface and enter the freeboard, at which the carryover occurs. If this height is above the transfer disengaging height (TDH), carryover is maintained at a constant level known as the saturation gas carrying capacity. Pressure drop across the bed, which is affected by the characteristics of bed particles, is an important variable to consider in developing

a bubbling fluidized bed . It determines the size and rating of the blower needed to supply air to the fluidized bed. Figure 1.5 shows the parts of a bubbling fluidized bed gasifier.

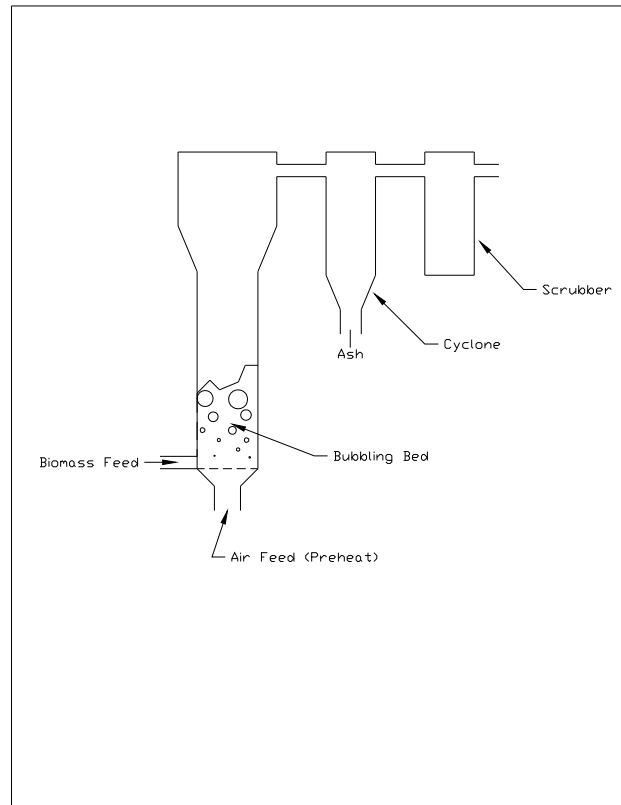

Figure 1.5. Fluidized bed gasifier

A fluidized bed gasifier consists of an inert bed material such as sand, ash or char, which acts as an effective heat transfer medium. In the operation of a fluidized bed gasifier, the bed is initially heated and the feedstock is introduced as soon as the temperature is high enough. The bed material aid in heat transfers and may provide a catalytic or gas cleaning action. This material is kept in a state of suspension, simulating a fluid by blowing the gasifying agent at a controlled flow rate through the distributor plate.

Fluidized bed gasifiers have several advantages over other gasification reactors, including strong gas solids contact, excellent heat transfer characteristics, better temperature control, large heat storage capacity, good degree of turbulence, and high volumetric capacity. The disadvantages of fluidized bed reactors are large pressure drop, particle entrainment, and erosion

of the reactor body.

Because fluidized bed reactors operate at pressures slightly above atmospheric levels, their design and construction must prevent leakage. Hence, the fuel feeding system must be equipped with a pressure-locking device. Because the fuel is immediately gasified as it is fed into the bed, these gasifiers respond slowly to load changes. Simply put, there is no buffer stock of gas within the gasifier to supply fluctuating demands. Due to their complicated and expensive control systems, fluidized bed gasifiers appear to be commercially viable over 30 MW thermal outputs.

Like all fluidized models, bubbling fluidized beds are categorized as either a single fluidized bed and multi-fluidized beds.

1.4.2.1.1. Single fluidized bed gasifier

This system consists of only one bed into which the feedstock and gasifying agent enter and out of which the produced gas and char exit. The advantages of the system include: (1) lower cost than dual and multi-fluidized beds; (2) less maintenance; and (3) the produced gas is ready for utilization. On the other hand the system has some disadvantages. These include: (1) heating value of the produced gas is lower than that produced by the dual bed; (2) inorganic materials in the feedstock cannot be separated; and (3) pyrolysis occurs at the bottom of the gasifier leading to a non-uniform temperature distribution.

One of the earliest studies of thermochemical conversion in a single fluidized bed was carried out by Morgan et al. (1953). They studied distillation of hardwood in a 0.051 m single fluidized bed batch reactor. The bed material was powdered hardwood and the fluidizing gas was preheated nitrogen. They obtained charcoal, liquid, and gas yields of 32%, 29% and 16% (by weight of the initial charge) after operating for 30 minutes at 673 K. The remaining 23% loss was attributed to tar and char accumulation within the sampling train and the inaccuracies in the gas yield measurements.

1.4.2.1.2. Dual and multi-fluidized beds gasifier

This system consists of more than one bed. The first bed is usually used to burn some of the char to produce the energy for the second bed, which is where the pyrolysis occurs. The advantages of the dual bed system include: (1) the gas heating value is larger because char

combustion occurs in a separate reactor and hence the combustion gas does not dilute the pyrolysis gas; (2) inorganic materials in the feed can be separated; and (2) heat of pyrolysis in the reactor is distributed evenly, thus pyrolysis occurs at a relatively uniform temperature. Higher construction costs and greater maintenance are the disadvantages of this system.

1.4.2.2 Circulating fluidized bed gasifier

If the gas velocity in a bubbling fluidized bed is further increased, more particles will be entrained in the gas stream and leave the reactor. Eventually the transport velocity for most of the particles is reached, and the vessel can be quickly emptied of solids unless additional particles are fed to the base of the reactor. If the solids leaving the vessel are returned through an external collection system, the system is called a circulating or fast fluidized bed (CFB) system (Figure 1.6). The streams of particles moving upward in the reactor are at solid concentrations well above that for dilute phase transport. Compared to conventional furnaces, circulating beds have a higher processing capacity, better gas-solid contact, and the ability to handle cohesive solids that might otherwise be difficult to fluidize in bubbling fluidized beds. Despite these advantages, circulating fluidized beds are still less commonly used than bubbling models, primarily because their height restricts their applications in terms of cost analysis.

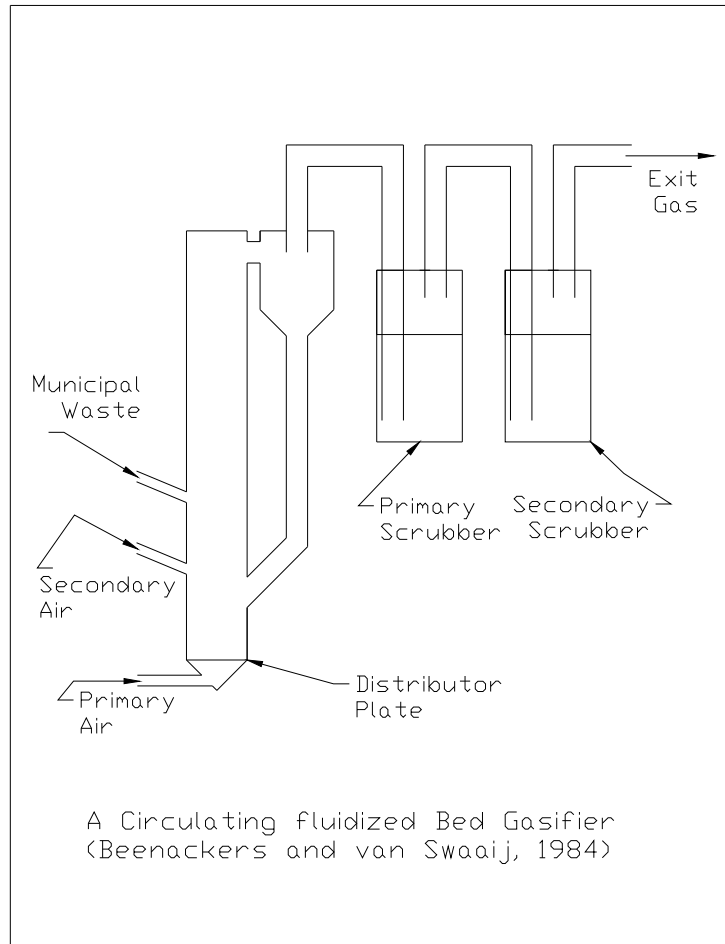

Figure 1.6. Circulating fluidized bed gasifier

1.4.2.3 Spouted fluidized bed

A spouted fluidized bed consists of a bed of coarse particles partly filling the vessel, which also has a relatively large control opening at its base. Gas is injected through this aperture. With sufficient gas flow, the particles in the gas can be forced to rise in a fountain at the center of the bed and develop cyclic motion on the bed as a whole. The bed motion can be assisted by additional air at the base to produce a spouted fluidized bed. Spouted fluidized bed gasifiers have been used to gasify coal of various ranks in air-steam and/or oxygen-steam mixtures at atmospheric and elevated pressures. The minimum particle diameter at which spouting appears to be practical is about 1 mm. This particle size is close to the value above which the gas-solid contacting effectiveness of fluidized beds is seriously impaired due to bypassing of gas in the

form of large bubbles. The total pressure drop across a fully spouting bed is always lower by 20% than that required for good quality aggregative fluidization.

1.4.2.4 Swirling fluidized bed

A swirling fluidized bed consists of a bed of granular material in a cylindrical column. Primary air is introduced at the bottom of the bed through a distributor plate at a sufficient velocity to fluidize the bed material in a bubbling regime. Secondary air is introduced through one pair of openings (at least) into the freeboard region of the column to create swirl or vortex flow. The injection of secondary swirling air into the freeboard helps to achieve high relative movement between the air and the fuel particles. A centrifugal action ensures that all fuel particles above a certain minimum size are retained in the combustion chamber and prevented from being elutriated. This increases the gas residence time and the degree of mixing (gas-gas and gas-solids) which increases the rate of reactions in the freeboard. Swirling fluidized beds meet the requirements of combustion by achieving complete combustion and have limited application for gasification. They may be more suited to steam gasification.

1.5. Gasification Chemical Reactions

Gasification of solid waste with reactive gases such as air, steam, CO₂ and O₂ as well as secondary reactions such as the water gas shift reaction, methanation, tar cracking and reforming of tars and heavy hydrocarbons are normally favored at high temperatures (>600°C). The char-gas reaction (C-CO₂ and C-H₂O) controls the ultimate conversion of the char, thus their products can dominate the final gas. The composition of the final product gas is dependent on the degree of equilibrium attained by various gas phase reactions.

1.5.1. Heterogeneous reactions

The principle gasification reactions and standard enthalpy change are:

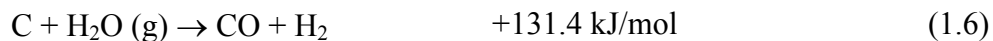
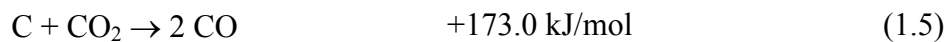
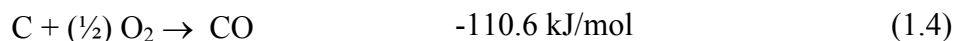
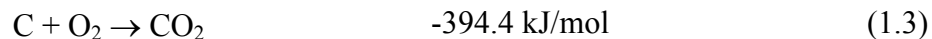



The combustion reaction occurs in the presence of free oxygen, is highly exothermic, and very fast. The combustion reaction (1.3) and (1.4) provides the energy necessary to sustain the endothermic gasification and other reactions. Other oxidation reactions are also exothermic.

1.5.2. Homogenous reactions

The following gas phase reactions occur in a biomass gasifier to an extent dependent on the operating conditions.

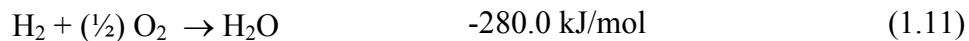
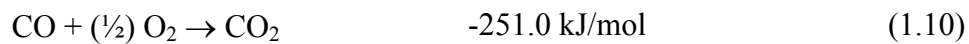
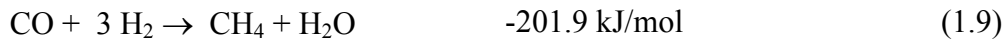
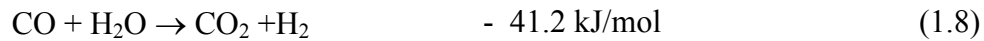

Other important secondary reactions occur under appropriate conditions (temperature, pressure) involve decomposition of heavy hydrocarbons and tars to carbon and low molecular gaseous products.

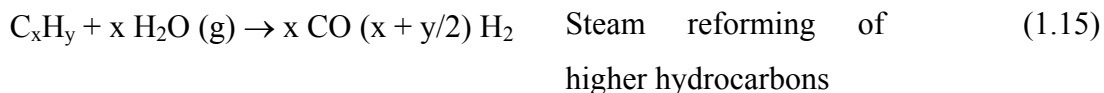
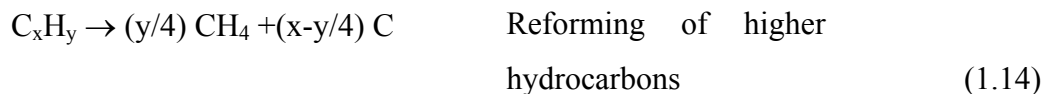
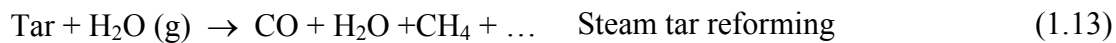
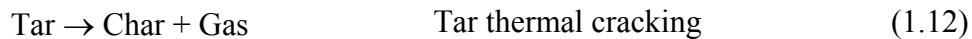

1.6. Factors Influencing Gasification Process

Several variables seem to affect the gasification process, product composition, and distribution, including bed temperature, bed pressure, bed height, fluidization velocity, gasifying medium, equivalence ratio, feed material moisture content, particle size, air to steam ratio, and

presence of catalysts. These parameters are quite interrelated and each of them affects the gasification rate, process efficiency, product gas heating value and product distribution.

1.6.1. Bed temperature

The gasification rate as well as the overall performance of the gasifier is temperature-dependent. All gasification reactions are normally reversible and the equilibrium point of any of the reactions can be shifted by changing the temperature.

As part of a wider investigation, Harris et al. (2005) presented gasification conversion data for a suite of Australian coals reacting with oxygen/nitrogen mixtures at 2.0 MPa pressure and at temperatures up to 1773 K. Combustible gas concentration increased with increases in temperature. Char yield decreased with increases in temperature. Scott et al. (1988) reported that the product gas yield from maple sawdust (1.4% M.C.) increased as the reactor temperature increased whereas the liquid and solid products decreased with increases in temperature. The decreasing amount of char indicated that the conversion increased with increases in temperature. Voloch et al. (1983) found the conversion of corncobs to increase from 94% at 500°C to 99% at 900°C in air gasification. Elliot and Sealock (1985) reported 10% and 50% wt basis conversion of lignin at 350 and 450°C, respectively. Alves and Figueiredo (1989) reported that tar production at low temperatures (below 500°C) was found to increase initially with increases in temperature and then drop with further increases in temperature. Utioh et al. (1989) reported increases in hydrocarbon gases, especially CH₄ and C₂H₄ (ethylene) with increases in temperature. The yield of higher hydrocarbons (C₃-C₈) decreased with increases in temperature above 650°C, which indicated the onset of cracking/reforming reactions. Other gas components (H₂ and CO), also increased with increases in temperature (Font et al., 1988). The heating value of the producer gas is also influenced by temperature. Sadakata et al. (1987) found the calorific value of crop residue gasification producer gas increased steadily up to 700°C and then decreased. The increase in the gas heating value is due to the increase in concentrations of CO, H₂ and hydrocarbon gases in the gas mixture. The decline at higher temperatures is probably due to the cracking of hydrocarbons. The first-order rate constant of gasification was found to increase with temperature in accordance with the Arrhenius equation (Edrich et al., 1985). Brink (1981) pointed out that gasification rates are too fast and are controlled by heat and mass transfer

rates above 900°C while in the range of 600-900°C, the gasification reactions are rate controlling. Below 600°C, the gasification reaction rates are too slow.

1.6.2. Bed pressure

Bed pressure has been reported to have a significant effect on the gasification process. Nandi and Onischak (1985) found the weight loss during devolatilization of crop residues in N₂ atmosphere at 815°C, to decrease with increases in pressure. However, at a constant temperature, the first-order rate constant (k) for the char gasification increased as pressure increased. Using a gasifying medium of 50:50 H₂O/N₂ at a temperature of 815°C, the values of the rate constant (k) for wood char were 0.101, 1.212 and 0.201 min⁻¹ at pressures of 0.17, 0.79 and 2.17 MPa, respectively. McLendon (2003) co-gasified mixtures of coal and biomass in a jetting, ash-agglomerating, fluidized-bed, pilot scale gasifier at an operating pressure of 3.0 MPa. Feed mixtures ranged up to 35% by weight biomass. The results of gasification tests of sub-bituminous coal/sawdust mixtures showed few differences in operations compared to sub-bituminous coal only tests. The bituminous coal mixture had marked differences. Transport properties of coal/biomass mixtures were greatly improved perhaps due to the high pressure used in this study. Plante et al. (1988) reported that the gasification rate of crop residues chars prepared at atmospheric pressure increased with increases in pressure. The increase was more significant at high temperatures (900-950°C). Nandi and Onischak (1985) found weight loss during devolatilization of crop residues in an N₂ atmosphere at 815°C to decrease with increases in the pressure. Increasing the pressure caused a significant increase in methane yield (Liinanki et al., 1985). Another advantage of pressurized reactors is the high reaction rate which allows for a smaller reactor vessel. Richard et al. (1985) found that H₂/CO and CO₂/CO molar ratios increased with an increase in the total pressure of a char-steam gasification process.

1.6.3. Bed height

At a given reactor temperature, a longer residence time (due to higher bed height) increases total gas yields. Sadaka et al. (1998) showed that a higher bed height resulted in greater conversion efficiency as well as a lower bed temperature due to the fly-wheel effect of the bed material. The fly-wheel effect is significantly reduced when the amount of bed material is reduced thereby resulting in higher bed temperature. Their results also reported that increasing

the bed height increases the bed pressure drop in the dense bed but resulted in no significant changes in the freeboard region. Font et al. (1988) reported increases in H₂, CO, CO₂, CH₄ and C₂H₄ when the residence time was increased as a result of increased bed height. A long residence time allows for increased heat transfer and, hence, increased char and tar conversion to gas. Beaumont and Schwob (1984) found that at a temperature of 350°C, water yield increased with increases in vapor residence time during the pyrolysis process of wood in an N₂ atmosphere.

1.6.4. Fluidization velocity

Fluidization velocity plays an important role in the mixing of particles in the fluidized bed. In air gasification systems, the higher the fluidization velocity the higher the bed temperature and the lower the produced gas heating value due to increased amounts of oxygen and nitrogen in the inlet gas to the system. Sadaka et al. (2002) reported that the higher heating value reached its peak value at a fluidization velocity of 0.28 m/s but remained fairly constant at the fluidization velocities of 0.33 and 0.37 m/s. However, Raman et al. (1980) tested the gasification of feedlot manure with different superficial gas velocities. They found that the tested range of superficial velocity did not have a significant influence on produced gas yield, composition, or heating value due to the tested small range.

1.6.5. Equivalence ratio

The equivalence ratio has the strongest influence on the performance of gasifiers because it affects bed temperature, gas quality, and thermal efficiency. Increasing the equivalence ratio resulted in lower pressure drops both in the dense bed and the freeboard regions when the gasifier operated at different fluidization velocities and bed heights.

Schoeters et al. (1989) reported that high equivalence ratios increased the gas production rate in air gasification. The gasifier temperature was found to increase with increases in the equivalence ratio because of increases in the exothermic reactions. On the other hand, a very low equivalence ratio results in very low bed temperatures, thus producing a lower gas and higher tar yields. Ergudenler and Ghaly (1992) reported that the combustible components and the heating value of the produced gas decreased with decreases in the equivalence ratio. At the equivalence ratios of 0.25, 0.20 and 0.17, the higher heating value of the produced gas were 6.48, 6.19 and 5.98 MJ/Nm³, respectively.

1.6.6. Moisture content of feed material

The moisture content of feed material affects reaction temperature due to the energy required to evaporate water in the fuel. Therefore, the gasification process takes place at a lower temperature. Elliot and Sealock (1985) reported on the conversion of lignin (of less than 10%wt basis moisture content) at 350°C and about 50% wt moisture content at 450°C. They found a direct correlation between high moisture content and high volumes of produced char. They reported a decrease in gasifier temperature with increases in fuel moisture content.

1.6.7. Particle size

The feed particle size significantly affects gasification results. The coarser the particles, the more char and less tar they produce. The rate of thermal diffusion within the particles decreases with increased particle size, thus resulting in a lower heating rate. For a given temperature, the produced gas yield and composition increased with a decrease in manure particle size as reported by Raman et al. (1980). The gas yield for the smallest size fraction (-14 to +40 mesh) increased from 0.51 m³/kg at 900 K to 0.81 m³/kg at 1010 K. For the largest size fraction (-2 to +8 mesh), the gas yield increased from 0.10 to 0.60 m³/kg for the same temperature range. The heating value versus temperature plots for each particle size fraction were parabolic with the maximum heating value aligned with the smallest particle size fraction (18.0 MJ/m³ at 1010 K). For the largest particle size fraction, the heating value increased from 14.3 MJ/m³ at 900 K to a maximum of 19.8 MJ/m³ at 980 K and then decreased to 12.0 MJ/m³ at 1010 K. Edrich et al. (1985) found the gasification rate to depend on particle size. During the gasification of wood in a fixed bed gasifier, the gasification rate increased from 0.1 to 1.0 min⁻¹ when the particle size was decreased from 19.05 to 5.00 mm.

1.6.8. Air/steam ratio

Increasing the air to steam ratio increases the gas heating value until it peaks. Tomeczek et al. (1987) used an air-steam mixture in the gasification process of coal in a fluidized bed reactor. The results showed that the influence of steam-to-air ratio on char was particularly strong at lower ratios due to the fact that the steam released at the devolatilization stage contributed to the gasification process even in the case when steam was not added. When the

steam-air ratio increased, the heating value increased, reaching its peak at 0.25 kg/kg. Schoeters et al. (1989) investigated the effect of the air-to-steam ratio on the gasification of wood shavings. An increase in the steam flow rate resulted in an increase in the heating value and the energy recovery because the reactor was heated from outside, which helped to keep the temperature constant without any adjustment of the flows. Halligan et al. (1975) gasified feedlot manure using a mixture of air and steam in a bed consisting exclusively of the feed material. Over a temperature range of 966 to 1069 K, increasing the steam-to-air ratio increased the gas volumetric yield and the heating value from 0.6 to 1.3 m³/kg and from 8.7 to 9.8 MJ/m³, respectively. Energy recovery and carbon conversion also increased with temperature from 23 to 49% and 20 to 50%, respectively.

1.6.9. Presence of catalysts

Commercial and non-commercial catalysts were tested in various gasification processes. One of the main problems in the catalytic steam reforming of tar is the carbon deposition on the catalyst from the carbon's high aromatic character. Various catalysts are used to enhance the quality of the producer gas and reduce the tar production rate. Srinakruang (2005) developed Ni on dolomite catalyst (Ni/dolomite). The developed catalyst offered high activity and stability under a short contact time for the gasification of tar by steam. The performance of the Ni/dolomite catalysts gave negligible carbon deposition, while the conventionally supported Ni catalysts gave large carbon deposition. It was found that the property and activity of the Ni/dolomite catalyst is significantly influenced by the temperature of the calcinations.

Fung and Graham (1980) showed that potassium carbonate and calcium oxide increased gas production in gasification processes. Rolin et al. (1983) reported that for wood gasification at 900°C, potassium carbonate is the most efficient catalyst of all carbonates (Na₂CO₃, K₂CO₃, CaCO₃, NaHCO₃ and KHCO₃) tested. Hallen et al. (1985) showed that adding alkali and cesium carbonates to crop residues either by solution impregnation or dry mix increased gas production in crop residue steam gasification.

Walawender et al. (1981) studied the effect of limestone as a bed additive in the steam gasification of manure in a 0.05 m I. D. reactor. Limestone was found to prevent agglomeration and affected the produced gas composition, yield, and heating value. With the addition of limestone to the bed, the produced gas concentrations of H₂, CO₂, CO and the gas heating value

were 45%, 28%, 15% and 12.4 MJ/m³, respectively under the operating temperature used. The effects of inorganic salts on the yields and distribution of products from air gasification of biomass in a fluidized bed was studied by Laichena (1993). Coffee husks and spruce sawdust mixed with inorganic salts (sodium tetraborate, potassium chloride and lithium chloride) were gasified at atmospheric pressure at temperatures ranging from 600°C to 800°C. The inorganic salts significantly affected both the yield and distribution of products. All of the inorganic salts increased the char yield but decreased the tar and moisture content of the product gas compared to the gasification of untreated feedstock under similar conditions. Tar reduction ranged between 11% and 89% while the tar content of the product gas ranged between 2.3 g/Nm³ and 9.2 g/Nm³. The carbon conversion ranged between 64 and 99%. At high operating temperatures, silica sand agglomerated causing channeling of the bed and consequent de-fluidization.

Baker et al. (1985) studied catalysts in gas-phase reactions in steam gasification of biomass by passing raw gasification products through a catalyst bed. Alkali carbonates (Na₂CO₃ and K₂CO₃) either impregnated on wood or on an alumina support produced tar-free gas at 750°C. The impregnated alkali carbonates enhanced char production and CH₄ reformation. The Na₂CO₃ catalyst is very good in terms of H₂ and CO and does not reduce CH₄ and other hydrocarbons. Reduction of CH₄ and other hydrocarbon yields by alkali carbonates have been reported by other authors (Brown et al., 1984).

Mudge et al. (1988) studied the gasification of biomass with steam and CO₂ in the presence of alkali carbonates at 750°C. The alkali carbonates K₂CO₃ and Na₂CO₃ were impregnated on wood at two concentrations, 8% and 4% for K₂CO₃, 6% and 3% for Na₂CO₃. Both catalysts increased the char gasification rates, although potassium carbonate was more effective than Na₂CO₃. Generally, the reaction rates for steam-char were higher than the rates obtained with CO₂. The catalyst increased the total gas yields, enhanced H₂ and CO₂ production, and decreased CO concentration in the product gas.

1.7. Limitations Associated with Gasification Process

Although gasification processes have been highly developed, there are still several limitations. Some of these limitations are related to feedstock characteristics while others are related to the overall design of gasifiers.

1.7.1. Moisture Content

The operation of a gasifier is affected by the moisture content of the feedstock. The limiting value of moisture mass fraction varies with fuel energy content. The higher the moisture content of the feedstock, the lower the bed temperature due to the energy required to evaporate the water from the feedstock.

Butuk and Morey (1987) studied the performance of a laboratory-scale fluidized bed gasifier 0.152 I.D to gasify hammer-milled corncobs with 10 and 22% wet basis moisture contents and a 710°C bed temperature. Their results showed that the heat outputs decreased from 132.5 to 84.3 MJ/h when the moisture content was increased from 10 to 20%. Black et al. (1980) studied the effect of feedstock moisture content on the produced gas heating value when gasifying wood. The heating value of the produced gas decreased from 4.5 MJ/Nm³ at 20% moisture content (wt. basis) to 1.5 MJ/Nm³ at 50% moisture content (wt. basis).

1.7.2. Feeding Systems

The size, shape, density, moisture content and composition of the fuel are the major factors affecting the type of the fuel feed mechanism to be used. Several feeding mechanisms were developed to accommodate the wide variety of feedstock, which includes direct feeding to the bed and over-the-bed feeding.

In direct feeding, if the feeding unit is not isolated from the reactor, tar flows back, condenses in the feeding mechanism, and sticks to the screw and shaft. Also, toxic and combustible gas back-flow from the gasifier might cause explosions. Therefore, a combination of purge gas, airlocks and lock hoppers are used to seal the hopper against the slight positive pressure of the bed, this minimizing the possibility of gas back-flow.

Over-the-bed feed systems are usually less troublesome because there is no direct contact between the hot bed material and the feeder. However, this type of feeding mechanism is restricted to higher density and/or bigger particle size feed materials, which are less likely to be carried out of the reactor by the outgoing gases. Due to particle emissions, over-the-bed feeding usually results in a dirty gas, which increases gas clean-up costs and fuel loss.

It is very difficult to handle and feed fluffy feedstock to the reactor because of the low density, irregular shape and fluffy structure. Bilbao et al. (1987) showed that the mixing characteristics of the sand/straw mixture are mostly dependent on the method and equipment of

feeding straw to the fluidized bed reactor. Ghaly et al. (1989) stated that straw, which has extremely low density, must be fed directly into the bed to avoid its escape from the reactor. Better mixing and fuel distribution characteristics within the bed were experienced with pneumatic transport feeding systems. It is, however, not a common application because of its dependency on the physical properties of the feedstock.

1.7.3. Ash Deformation Temperature

The deformation temperatures of ash and slag are affected by the composition of the ash and its concentration. Melted ash can clog the grate and ash handling becomes a critical problem. The constraint that controls the operating temperature of gasifiers is the operating below the initial deformation temperature (as low as 900°C). Ghaly and Al-Taweel (1990) reported deformation temperatures of -900-1050°C, -730-987°C, -750-1043°C and 800-931°C for wheat, barley, oats and rye straws, respectively. Perkins et al. (1984) reported a significant decrease in the melting temperature of the ash in the presence of large amounts of low melting temperature mineral oxides such as Na₂O and K₂O. Huffman et al. (1981) stated that the most desirable chemical constituent of ash is Al and the most undesirable constituents are K, Ca and Fe. Imc (1980) reported rapid agglomeration of the ash/bed material mixture during fluidized bed gasification of waste wood when the temperature was increased above 900°C. The bed fused completely above 1000°C.

Carre et al. (1988) reported that the high volatile content, which burns at high temperatures causing severe slag formation and operational problems, cause difficulties in keeping the reactor temperature below the ash melting temperature. The use of automatic ash removal systems and/or movable grates may reduce these problems. Studies by Ergudenler and Ghaly (1992) showed that K₂O (which has low melting temperature and high weight percentage in the ash of wheat straw) is the major contributor to the agglomeration process. They reported that a fluidized bed of silica sand agglomerated at around 800°C in the presence of straw ash results in serious channeling and de-fluidization.

1.7.4. Particle mixing and segregation

The design of fluidized bed reactors becomes extremely important because both the axial and radial transport of solids within the bed influence gas-solid contacting, thermal gradient and

the heat transfer coefficient. Segregation in a fluidized bed is affected by the particle density, shape, size, superficial gas velocity, mixture composition, bed aspect ratio and jetsam fraction.

Cranfield (1978) investigated solid mixing in three-dimensional fluidized beds of large size particles. The vertical mixing in the fluidized bed occurred due to bubble-induced drift. The net vertical transport of particles in freely bubbling beds was considered to be a function of bubble flow, time and bed level. The upper part of the bed attained a fairly uniform composition while the lower component sank (jetsam) to form a concentrated bottom layer. The concentration of jetsam in the upper region (compared with its overall value) is a good measure of the degree of mixing achieved. Bilbao et al. (1988) encountered severe mixing problems in fluidized beds when the fuel particles varied in size, shape and density. Due to the high level of segregation, sand settled at the bottom and the straw tended to rise to the top. This created temperature gradients inside the fluidized bed that decreased the conversion efficiency and caused tar formation and agglomeration. Ghaly et al. (1989) stated that an effective mixing of straw with the inert bed material is necessary to obtain a uniform distribution of fuel particles throughout the bed and thus, a uniform temperature distribution. Bilbao et al. (1988) showed that for given sizes of sand and wheat straw, achieving a good mix depends on the relative concentrations of both solids in the bed and the gas velocity.

1.7.5. Entrainment and elutriation

Entrainment, elutriation, and carryover are technical terms used interchangeably to describe the ejection of particles from the surface of a bubbling bed, fractionation in the freeboard region and the removal of particles from the fluidized bed unit in the gas stream. Entrainment is expected to be influenced by many factors such as fluidizing gas properties (superficial gas velocity, gas density, viscosity and relative humidity) the solid properties (particle size, particle size distribution and particle density) and other factors (bed diameter, bed depth, gas distribution and internal surfaces).

Entrainment or carryover of solids from fluidized beds is economically and environmentally unacceptable. In the case of particle emission, gas-cleaning equipment must be provided at extra capital and operating costs. The design of such equipment requires the knowledge of the total quantities of solids carried over, their size distribution and their concentration in the gas stream. Unfortunately, providing this information from basic principals

is difficult because of the complexity of the two phase flow in the freeboard. Horio et al. (1980) reported that the solid concentration in the freeboard is non-uniform, with a downward moving denser stream of solids at the wall and diluted upward in a central core. Geldart (1972) showed that fine particles interact with coarse ones in the freeboard. The height is larger than would be expected as determined by their terminal velocities.

1.8. Reported Findings in Gasification Research

In this section, several findings of the gasification research will be summarized to identify the crop residues and waste gasification phenomenon.

1.8.1. Crop residues gasification

Pan et al. (2000) conducted experiments involving the co-gasification of residual biomass/poor coal blends and gasification of individual feedstock used in the blends in a bench scale, continuous fluidized bed reactor working at atmospheric pressure. Two types of blends were prepared, mixing pine chips with low-grade black coal and Sabero coal, a refuse coal from Sabero, Spain, in the ratio range of 0/100–100/0. Experimental tests were conducted using as gasification agent mixtures of air and steam at gasification temperatures of 840–910°C and superficial fluidized gas velocities of 0.7–1.4 m/s. Feasibility studies were very positive, showing that blending effectively improved the performance of fluidized-bed co-gasification of the low-grade coal, and the possibility of converting the refuse coal to a low-Btu fuel gas. Their study indicated that a blend ratio with no less than 20% pine chips for the low-grade coal and 40% pine chips for the refuse coal are the most appropriate. The dry product gas low heating value augments with increasing blend ratio from 3.7 to 4.5 MJ/Nm³ for pine chips/low-grade coal, and from 4.0 to 4.7 MJ/Nm³ for pine chips/refuse coal. Dry product gas yield rises with the increase of the blend ratio from 1.80 to 3.20 Nm³/kg (pine chips/low-grade coal), and from 0.75 to 1.75 Nm³/kg (pine chips/refuse coal), respectively. About 50% thermal efficiency was achieved for the two types of blend.

1.8.2. Straw gasification

Sadaka et al. (2002) developed a fluidized bed gasifier to gasify wheat straw in an air/steam mixture. Their study showed that the performance of the fluidized bed gasifier (gasifier

temperature, pressure drop, higher heating value and gas production rate) was affected by fluidization velocity, steam flow rate and biomass to steam ratio. The temperature of the dense bed reached its maximum (891°C) indicating that the agglomeration problem was overcome by injecting an air/steam mixture. The higher heating value of the producer gas and the gas production rate reached their maximum of 10.63 MJ/Nm³ and 2.47 Nm³/min, respectively. The bed pressure drop ranged between 37.2 to 51.6 cm H₂O, indicating a good fluidization quality.

Risens et al. (2003) studied the influence of calcium addition in straw gasification. The effect of calcium addition as calcium sugar/molasses solutions to straw significantly affected the ash chemistry and the ash sintering tendency but much less the char reactivity. Walawender et al. (1982) gasified straw with steam in a 0.23 m diameter fluidized bed reactor over a temperature range of 552 to 757°C. The fraction of the feed converted to gas ranged from 32% at the temperature of 552°C to 73% at the temperature of 757°C. The heating value of the gas exhibited a parabolic variation with temperature with a maximum value of 12.3 MJ/m³ obtained at 672°C.

1.8.3. Rice husk gasification

Yin et al. (2002) designed and installed a circulating fluidized bed (CFB) biomass gasification and power generation system (BGPG) for rice husk to provide power for a rice mill with a capacity of 150 td⁻¹. The system consists of a CFB gasifier, a gas cleaner (including an inertial separator, a cyclone separator, a venture and two water scrubbers), and power generation subsystem (containing five parallel gas engines rated 200 kW each), as well as a wastewater treatment system. It was found that the system can be operated stably within the temperature range of 700°C to 850°C; its optimal condition was reached when the workload was increased above 800 kW. The main performance indices are: capacity, 1500 kg h⁻¹; gasification efficiency, 65%; rice husk consumption, 1.7–1.9 kg kWh⁻¹; total efficiency, about 17%. The reliability of the BGPG system has been proven through two years of operation (about 10,000 h). The total investment is \$510,000 USD, the unit investment is \$370 USD kW⁻¹, the operation cost is 0.032 USD kW⁻¹, and the payback period is not more than two years.

The gasification of rice husk was also studied by Chen and Rei (1980) over a temperature range of 600 to 700°C. They used an electrically heated 0.05 m I. D. fluidized bed reactor. The bed consisted of fused alumina sand and the fluidizing medium was super heated steam. The gas yield increased from 0.38 to 0.55 m³/kg and the heating value varied from 12.8 to 18.5 MJ/m³.

Over this temperature range, H₂, CH₄, CO and CO₂ concentrations in the produced gas varied from 3.6 to 13.1%, from 14.4 to 13.5%, from 52.2 to 51.1% and from 23.0 to 14.6%, respectively. The balance of the product gas was made up of higher hydrocarbons including ethane, ethylene and propylene.

1.8.4. Cotton gin trash gasification

Some agricultural and waste biomass samples such as sunflower shell, pinecone, rapeseed, cotton refuse and olive refuse were first pyrolyzed in nitrogen. Their chars were then gasified in a gas mixture of steam and nitrogen. Pyrolysis of the biomass samples was performed at a heating rate of 20 K/min from ambient to 1273 K in a dynamic nitrogen atmosphere of 40 cm³ min⁻¹. It was concluded that gasification characteristics of biomass chars were fairly dependent on the biomass properties such as ash and fixed carbon contents and the constituents present in the ash. Different mechanisms in the three temperature intervals, namely water adsorption at lower temperatures, decomposition of hydroxide minerals to oxide minerals and formation of carbon monoxide at medium temperatures and production of hydrogen at high temperatures govern the behavior of the char during the gasification process.

Singh et al. (1986) investigated the steam gasification of cotton wood branches in a fluidized bed reactor and compared the produced gas characteristics with those for pure cellulose. With the exception of the gas heating value, the energy recovery, carbon conversion and mass yield of the gas obtained from cotton wood were found to be lower than those obtained from pure cellulose. Groves et al. (1979) studied fluidized bed air partial oxidation of cotton gin trash over the temperatures range of 649 and 871°C in a 0.3 m I. D reactor. The off-gas heating value and the energy recovery increased from 3.4 to 4.3 MJ/m³ and from 27 to 53%, respectively.

1.8.5. Corn cobs gasification

Results for the gasification of corncobs over a temperature range of 500 to 1000°C were presented by Epstein et al. (1978). Produced gas yield (reported as a mass fraction of the feed) increased from 0.17 to 0.60 kg/kg and tar yield decreased from 0.30 to 0.22 mg/Nm³. The gas contained large amounts of CO and H₂ and the heating value varied from 1.4 to 10.9 MJ/m³.

1.8.6. Sawdust gasification

Wander et al. (2004) reported that the technology of wood gasification can produce a gas capable of being burned in an internal combustion engine, as long as it is appropriately cleaned. In order to assess the performance of the wood residues gasification process, a small, fixed bed, downdraft, stratified and open-top gasifier was built. This gasifier, whose capacity was around 12 kg/h, has an internal gas recirculation, new to this type of gasifier, which can burn part of the gas produced to raise the gasification reaction temperature.

Results from the gasification of oak sawdust in a pilot plant were reported by Beck and Wang (1980). The off-gas yield ranged from 1.1 m³/kg at 600°C to 1.3 m³/kg at 800°C and the heating value was greater than 11.2 MJ/m³ for all temperatures. Lian and Findley (1982) studied the air gasification of oak sawdust and found that the tar and char yield decreased linearly with temperature from 6% of the dry wood weight at 650°C to 0.5% at 800°C. They tested the effect of airflow rate on the performance of the gasifier and concluded that the total carbon-to-nitrogen ratio in the dry gas gave the best correlation with the concentrations of carbon, hydrogen and the higher heating value.

1.8.7. Cellulose material gasification

Walwender et al. (1981) gasified alpha cellulose in a bench-scale fluidized bed reactor using steam over a temperature range of 600 to 800°C. The major components of the produced gas were H₂, CO₂, CO and CH₄ and the volumetric gas yield was 0.5-1.4 m³/kg. The average gas higher heating value was 11.8 MJ/m³. The energy recovery and carbon conversion were within the 32-90% range. Hoveland et al. (1985) investigated the steam gasification of alpha cellulose at elevated free-board temperatures and confirmed an earlier hypothesis that proposed the existence of two temperature regimes for cellulose gasification, one below 567°C dominated by volatile cracking and the other above 567°C dominated by the water gas shift reaction.

1.8.8. Manure gasification

Sweeten et al. (2003) reported that feedlot manure has approximately half the heating value of coal, twice the volatile matter of coal, four times the N content of coal on heat basis. And due to soil contamination during collection, the ash content is almost 9–10 times that of low ash (5%) coal. The addition of 5% crop residues had little apparent effect on heating value. The

fuel N per GJ is considerably higher than coal, which may result in increased NO_x emissions. The N and S contents per GJ increase with composting of feedlot manure while the volatile ash oxide decreases with composting. Based on heating values and alkaline oxides, partial composting seems preferable to a full composting cycle. Even though the percentage of alkaline oxides is reduced in the ash, the increased total ash percentage results in an increase of total alkaline oxides per unit mass of fuel. The adiabatic flame temperature for most of the biomass fuels can be empirically correlated with ash and moisture percentage.

Raman et al. (1981) tested the gasification of feedlot manure with different superficial gas velocities. They found that the superficial velocity did not have a significant influence on produced gas yield, composition, or heating value. Walawender and Fan (1978) studied the air gasification of the feedlot manure and found that the produced gas yield, the higher heating value and the energy recovery increased by 131%, 77% and 244% when the temperature increased from 627 to 827°C. Halligan et al. (1971) gasified feedlot manure in a 0.05 m I.D. fluidized bed reactor. The fluidizing gas was a mixture of air and steam and the bed consisted of the feed material only. Over the temperature range of 693°C to 796°C, the off gas volumetric yield increased from 0.6 to 1.3 m³/kg and the gas heating value increased from 8.7 to 9.8 MJ/m³. The energy recovery and carbon conversion, also, increased from 23 to 49 % and from 20 to 50 %, respectively.

1.9. Gasification Applications

The produced gases from biomass gasification contain both combustible and non-combustible gases. The gas can be used in industrial application areas, irrigation, vehicular power, direct heating and production of value added products.

1.9.1. Gasification Technology for Power Generation and Industrial Applications

Currently, electric utilities and various industrial firms have expressed growing interest in finding economical and environmentally attractive methods of converting coal, wastes, and renewable fuels into replacement energy sources for use in combined heat and power applications. Biomass gasification will become significantly more attractive in industrial shaft power applications in rural area where grid electricity is either expensive or unavailable. In urban areas, the technology will be unattractive since grid electricity is usually a cheaper source of

energy.

One industry of prime interest is the forest industry, which supplies residues such as off-cuts, edgings, shavings and sawdust. Exact quantities of these depend upon the tree species being used the end product of the industry and, the efficiency of equipment employed. Combined, residues from such sources amount to about 50% of the total quantity of wood processed. However, these residues would be utilized by a system whose end product is producer gas. Another process of prime interest is the harvesting from which crop residues such as straw could be obtained. The exact quantities of these crop residues depend upon the species being harvested, the end product of the mechanism and the efficiency of equipment used. These residues could be utilized using a fluidized bed gasifier to produce gas. The gas could be used for direct burning to produce heat for kiln drying or steam generation. Steam could be used to generate electricity through turbines or for the production of mechanical power. Alternatively, the producer gas could be purified and used in internal combustion engines for the generation of mechanical power or on-site electricity.

1.9.2. Shaft Power

Shaft power is significantly demanded in developing countries for irrigation. Currently many fossil-powered units are in use; thus, where the interruption of fossil fuel supply is common, alternative energy sources such as producer gas are being sought.

As an alternative to internal combustion engines that use producer gas exclusively, there are engines that are operated on the dual-fuel principle. In such systems, the producer gas is used as a supplement to diesel fuel. Here the consumption of wood would be approximately 1.4 kg per kWh of shaft power. Where the availability of suitable biomass is scarce, the possibility always exists for the cultivation of trees that take approximately three to four years to mature. The possibility of using crop residues in gasifiers has also gained great attention. Although the questions about the technical suitability of crop residues as gasifier fuel remains to be answered, the concept shows promise.

A practical example of this technology is the use of gasifier-powered irrigation pumps in Brazil. The production of shaft power for irrigation pumps, sawmills, milling and shelling of maize in isolated rural communities in developing countries is a promising application of the producer gas. In these operations, a potential gasification feedstock is produced as part of the

process.

1.9.3. Vehicular Power

Inconvenience of gasifiers and the detrimental effects on engine performance are the main constraints of the gasification technology in vehicular applications. The next major limitation is the availability of readable biomass. During the two World Wars, wood chips and charcoal were suitable fuel for vehicle gasifiers. Fuel consumption will depend on factors such as type of gasifier, the load demand, driving conditions, type of vehicle and skill of the driver.

To avoid excessive engine wear and plugging of valves, gas supply lines and carburetors, the produced gas must be free of tars, dust, and acids. The presence of sticky and corrosive components (tars) is actually a major drawback to the introduction of biomass gasifiers in internal combustion engine application. However, with the present technology and continuing research, this problem should eventually be overcome. Due to its low heating value, producer gas causes a 30-40% de-rating of engine designed for gasoline fuel. An engine designed to use diesel fuel, on the other hand, is de-rated by only 10% to 20%. A dual fuel operation mode in which the engine draws 0-90% of its power output from producer gas and the rest from diesel oil is also possible.

The need to improve the power output from single-cylinder gasoline engine fueled with rice hull-produced gas was investigated by Camacho (1988). The normal compression ratio of the engine was 6.2. Standard engine cylinder head castings were machined to give compression ratios of 7.3 and 8.2. The engine test data indicated about a 10 to 16% power output for the 7.3 and 8.2, respectively, over the normal compression ratio 6.2. The comparison values for gasoline rated 3.7 kW engine on rice hull produced gas were: 1.42 kW vs. 1.57 kW (6.2 vs 7.3 compression ratio) and 1.42 kW vs 1.66 kW (6.2 vs 8.2 compression ratio).

1.9.4. Direct Heat Applications

Most commercial gasifiers currently in operation are used to produce heat rather than fuel for internal combustion engine, primarily because the requirements for heating fuel are less stringent. When the gasifier is close coupled to a burning system, higher temperatures can be reached and the efficiency and output of the overall system can be enhanced.

All gasifiers can be used to provide producer gas for combustion purposes. However, the

updraft is preferred in systems rated below 1 MW thermal power while the fluidized bed gasifiers are appropriate for ranges above this. Where fuel oil is being used to generate process heat, run furnaces or kilns, the gasification technology is a viable option.

The economic and technical problems of using direct heat gasifiers appear to be relatively minor. With more experience and better design, the range of potential uses will expand. However, fuel availability constraints will remain and, in the long term, will probably be the principal limitation on the spread of the biomass gasification technology. Countries that have large forest and agricultural resources are obviously suitable for the application of the gasification technology to direct heating. Logging residues, wood wastes and agricultural crops can all contribute to the heating needs of a wide range of nearby industries.

1.9.5. Production of value added products

Syngas is one of the main sources for hydrogen. The syngas is generally produced by steam reforming of natural gas or in some cases by gasification of heavy oil fractions. In refineries, hydrogen is used for the hydro-treating and hydro-processing operations. The specifications of hydrogen in the process industry are relatively mild, typical demands for hydro-cracker are H₂ content > 98% vol%, N₂ < 2% vol% and CO, CO₂ < 10-15 ppm.

For methanol production, the producer gas has to undergo an extensive treatment and processing to remove tars, acids and particulates. Carbon dioxide is also removed and a catalyst is used to bring up H₂O/CO molar ratio to about 2 (Brown, 2003). The resulting syngas is then converted to methanol by methanol synthesis reaction:



Methanol can be produced by means of the catalytic reaction of carbon monoxide and some carbon dioxide in the percentage range is necessary to optimize the reaction. Both reactions are exothermic and proceed with volume contraction; a low temperature and high pressure consequently favors them:

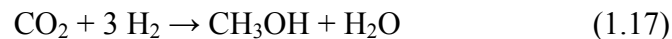

References:

- Alves, S.S. and J.L. Figueiredo. 1989. pyrolysis of wet wood. *Chemical Engineering Science*, 44(12): 2861-2869.
- Bailie, R.C. 1979. Hessleman Gas Generator Testing for Solar Energy Research Institute. Contract No. AH-8-1077-1.
- Baker, E. L. Mudge and W. Wilcox. 1985. Catalysis of gas-phase reactions in steam gasification of biomass. *Fundamentals of Thermochemical Biomass Conversion*. R. P. Overend, T. A. Milne and K. L. Mudge (eds). Elsevier Applied Science Publishers, London, UK, pp. 863-874
- Beaumont, O. and Y. Schwob. 1984. Influence of physical and chemical parameters on wood pyrolysis. *Ind. Eng. Chem. Process. Des. Dev.*, 23: 637-641.
- Beck, S.R. and M.J. Wang. 1980. Wood gasification in a fluidized bed. *Ind. Eng. Chem. Process. Des. Dev.*, 19(2): 312-317.
- Bilbao, R., J.L. Lezaun, M. Menendez and J.C. Abanades. 1988. Model of mixing / segregation for sand - straw mixtures in fluidized beds. *Powder Technology*, 56: 149-151.
- Black, J., K. Bircher and K. Chisholm. 1980. Fluidized bed gasification of solid wastes and biomass. *Thermal conversion of solid wastes and biomass*, Am. Chem. Society, Washington D.C.: 351-361.
- Brown, R. 2003. *Biorenewable Resources. Engineering New Products from Agriculture*. Iowa State Press. A Backwell Publishing Company.
- Boateng, A.A., W.P. Walawender, L.T. Fan and C.S. Chee. 1992. Fluidized bed gasification of rice hull. *Bioresource Technology*, 40(3): 235-239.
- Brink, D. 1981. Gasification. *Organic Chemicals from biomass*. Goldstein, I.S. (ed.). CRC Press. Boca Raton, Ch. 4: 45.
- Brown, M. L. Mudge and E. Baker. 1984. Catalysts for gasification of biomass. *Biotechnology and Bioengineering Symp.* No. 14:125-136..
- Butuk, N. R. Morey. 1987. Fluidized bed combustion and gasification of corn cobs. *Transactions of the ASAE*. 32(2): 543-547.
- Cao, Y., Y.Wang, J. Rieley and W. Pan 2005. A novel biomass air gasification process for producing tar-free higher heating value fuel gas. *Fuel Processing Technology*, Volume 87, Issue 4, April 2006, Pages 343-353

- Chen, C.C. and M.H. Rei. 1980. Gasification of rice husk. Presented at Bio-Energy 80 World Congress and Exposition, Atlanta, GA, April 21.
- Chen, T.H. and D.L. Day. 1982. Effect of Temperature change on the stability of thermophilic digestion of swine manure. *Agricultural Waste*. 16:313 – 317.
- Corella, J., J. Herguido and J. Gonzalez-Saiz. 1989. Steam gasification of biomass in fluidized bed-Effect of the type of feedstock. In: *Pyrolysis and Gasification*. Ferrero, G.L., K. Maniatis, A. Buekens and A.V. Bridgwater (eds). Elsevier Applied Science, London. pp. 618-623.
- Cranfield, R. 1978. Solids mixing in fluidized beds of large particles, *American Institute of Chemical Engineers Journal*. 74(176):54-59.
- Edrich, R., T. Bradley and M. Graboski. 1985. The gasification of ponderosa pine charcoal. *Fundamentals of Thermochemical Biomass Conversion*. R. P. Overend, T. A. Milne and K. L. Mudge (eds). Elsevier Applied Science Publishers, London, UK, pp. 557-566.
- Elliot, D.C. and L.J. Sealock. 1985. Low Temperature Gasification of Biomass Under Pressure. In: *Fundamentals of Thermochemical Biomass Conversion*. R. P. Overend, T. A. Milne and K. L. Mudge (eds). Elsevier Applied Science Publishers, London, UK, pp. 937-951.
- Epstein, E., H. Kosstrin and J. Alpert. 1978. Potential energy production in rural communities from biomass and wastes using a fluidized-bed pyrolysis system. *IGT Symposium on Energy from Biomass and Wastes*, Washington, D. C., Aug. 14-18.
- Ergudenler, A. 1993. Gasification of Wheat Straw in a Dual-Distributor Type Fluidized Bed Reactor. Unpublished Ph.D. Thesis. Technical University of Nova Scotia. Nova Scotia. Canada.
- Ergudenler, A. and A.E. Ghaly. 1992. Determination of reaction kinetics of wheat straw using thermogravimetric analysis. *Journal of Applied Biochemistry and Biotechnology*, 34/35: 75-91.
- Font, R., A. Marcilla, J. Deversa and E. Verdu. 1988. Gaseous hydrocarbons from flash pyrolysis of almond shells. *Ind. Eng. Chem. Res.*, Vol. 27: 1143-1149.
- Fung, D. and R. Graham. 1980. The role of catalyst in wood gasification. *Thermal conversion of solid wastes and biomass*. Jones, J.L. and Randing, S.B. (eds.) Am. Chem. Soc. Washington, D.C. 367-377.

- Geldart, D. 1972. The effects of particle size and size distribution on the behavior of gas fluidized beds. *Powder Technology*. 6:201-215.
- Ghaly, A.E. and A.M. Al-Taweel. 1990. Physical and Thermochemical Properties of Cereal Straws, *Energy Sources* 12:131-141.
- Ghaly, A.E., A.M. Al-Taweel, F. Hamdullahpur and I. Ugwu. 1989. Physical and chemical properties of cereal straw as related to thermochemical conversion. In: *Proceedings of 7th Bioenergy R&D Seminar*. E.N. Hogan (eds). Ottawa, Ontario, pp. 655-661.
- Groves, J.D., J.D. Craig, W.A. Le Pori and R. G. Anthony. 1979. Fluidized bed gasification of cotton gin waste. ASAE paper No. 79-4547. Presented at ASAE Winter meeting, New Orleans, Louisiana.
- Hallen, R.T., L.J. Sealock and R. Culleo. 1981. Influence of alkali carbonates on biomass volatilization. In: *Fundamentals of Thermochemical Biomass Conversion*. R.P. Overend, T.A. Milne and L.K. Mudge (eds). Elsevier Applied Science Publishers, London. pp. 157-162.
- Halligan, J.E., K.L. Herzog and H. W. Parker. 1971. Synthesis gas from bovine wastes. *Ind. Eng. Chem. Process Des. Dev.* 14 (1): 64-69.
- Harris, D., D.Roberts, D. Henderson. 2006. Gasification behavior of Australian coals at high temperature and pressure. *Fuel* 85 (2006) 134–142.
- Horio, M., A. Nonaka, Y. Sawa and I. Muchi. 1986. A new similarity rule for fluidized bed scale up. *Am. Inst. Of Chem. Eng. Journal*. 32(9): 1466-1482.
- Hoveland, A.D., W.P. Walawender, L.T. Fan and F.S. Lai. 1982. Steam gasification of grain dust in a fluidized bed reactor. *Transactions of ASAE*, 25(4): 1074-1080.
- Huffman, G.P. F.E. Huggins and G.R. Dunmyre. 1981. Investigation of the high temperature behaviour of coal ash in reducing and oxidizing atmospheres. *Fuel*, 60: 585-597.
- Imc. 1980. Application of fluid bed technology to the gasification of waste wood. Final report. Volume I. ENFOR Project c-12. DSS Contract 05SS. KL006-8-0249.
- Laichena, J.K.1993. The Effect of Inorganic Salts on the Gasification of Biomass in a Fluidized Bed. Unpublished Ph.D. thesis. Technical University of Nova Scotia. Nova Scotia. Canada.
- Lian, C.K. and M.E. Findley. 1982. Air blown wood gasification in large fluidized bed reactor. *Ind. Eng. Chem. Process Dec. Dev.* Vol. 21. : 699-701.

- Liinanki, L., P.J. Svenningsson and G. Thessen. 1981. Gasification of agricultural residues in a downdraught gasifier. In: *Energy From Biomass*. Palz, W., J.Coombs and D.O. Hall (eds). Elsevier Applied Science Publishers, London, UK, pp. 832-832.
- McLendon, T, A. Lui, R. Pineault, S. Beer and S. Richardson. 2004. High-pressure co-gasification of coal and biomass. *Biomass and Bioenergy* 26 (2004) 377 – 388
- Mermoud, F., F. Golfier, S. Salvador, Van de Steene and J Dirion. 2006. Experimental and numerical study of steam gasification of a single charcoal particle. *Combustion and Flame* 145 (2006) 59–79.
- Mudge, L., M. Brown and W. Wilcox. 1988. Bench scale studies on fluid bed pyrolysis of wood. Report PNL-6114, Pacific Northwest Laboratory, Richland, Washington.
- Nandi, S.P. and M. Onischak. 1981. Gasification of Chars Obtained from Maple and Jack Pine Woods. In: *Fundamentals of Thermochemical Biomass Conversion*. R.P. Overend, T.A. Milne and K.L. Mudge (eds). Elsevier Applied Science Publishers, London, UK, pp. 567-578.
- Pan, Y. G., E. Velo, X. Roca, J. J. Manya, L. Puigjaner. 2000. Fluidized-bed co-gasification of residual biomass/poor coal blends for fuel gas production. *Fuel*. Vol. 79:1317:1322.
- Plante, P. C. Roy and E. Chornet. 1988. CO₂ Gasification of Wood Charcoals Derived from Vacuum and Atmospheric Pyrolysis. *Canadian Journal of Chemical Engineering*, 66: 307-312.
- Raman, K.P., W.P. Walawender, L.T. Fan and C.C. Chang. 1981. Mathematical model for fluid bed gasification of biomass material. Application to feedlot manure. *Ind. Eng. Chem. Process Des. Dev.*, 20: 686-692.
- Richard. J., M. Cathonnet and J. Rowan. 1985. Gasification of charcoal: Influence of water vapor. *Fundamentals of Thermochemical Biomass Conversion*. R. P. Overend, T. A. Milne and K. L. Mudge (eds). Elsevier Applied Science Publishers, London, UK, pp. 589-599.
- Risnes, H., J. Fjellerup, U. Henriksen, A. Moilanen, P. Norby, K. Papadakis, D. Posselt, L. Sørensen. 2003. Calcium addition in straw gasification. *Fuel* 82 (2003) 641–651
- Rolin, A.C. Richard, G. Martin and X. Deglise. 1983. Influence of Catalysts on Gasification of Biomass at Short Residence Time. In: *Energy From Biomass*. Palz, W., J.Coombs and D.O. Hall (eds). Elsevier Applied Science Publishers, London, UK, pp. 901-901.

- Sadaka, S. S., A. E. Ghaly and M. A. Sabbah. 1998. Development of an air-steam fluidized bed gasifier. *Misr Journal of Agricultural Engineering*. Vol. 15(1): 47:52.
- Sadaka, S. S., A. E. Ghaly and M. A. Sabbah. 2002. Two phase biomass air-steam gasification model for fluidized bed reactor: Part I, II, III. *Biomass and Bioenergy*. 22: 439-487
- Sadakata, M., K. Takahashi, M. Saito and S. Takeshi. 1987. Production of gas fuel and char from wood, lignin and holocellulose by carbonization. *Fuel*, 66: 1667-1671.
- Schoeters, J., K. Maniatis and A. Buekens. 1989. The fluidized bed gasification of biomass: Experimental studies on bench scale reactor. *Biomass* 19: 129-143.
- Scott, D.S, J. Piscorz, M.A. Bergougnou, R. Graham and R.P. Overend. 1988. The Role of Temperature in Fast Pyrolysis of Cellulose and Wood. *Industrial Engineering Chemical Research.*, 27: 8-11.
- Singh, S.K., W.P. Walawender, L.T. Fan and W.A. Geyer. 1986. Steam gasification of cotton wood (branches) in a fluidized bed. *Wood Fiber Sci.*, 18: 327-344.
- Slapak, M. J., J. M. van Kasteren, A.A.Drinkenburg. 2000. Design of a process for steam gasification of PVC waste. *Resources, Conservation and Recycling*. Vol. 30:81–93.
- Srinakruang, J., K. Sato, T. Vitidsant and K. Fujimoto. 2005. A highly efficient catalyst for tar gasification with steam. *Catalysis Communications* 6 : 437–440
- Sweeten, J., K. Annamalai, B. Thien, L. McDonald. 2003. Co-firing of coal and cattle feedlot biomass (FB) fuels. Part I. Feedlot biomass (cattle manure) fuel quality and characteristics. *Fuel* 82: 1167–1182
- Tillman, D.A. 1987. Biomass Combustion. *Biomass: Regenerable Energy*. Hall, D.O. and Overend, R. P. (eds). John Wiley and Sons, pp. 203-219.
- Tomeczek, J., W.Kudzia, B. Gradon and L. Remarczyk. 1987. The Influence of Geometrical Factors and Feedstock on Gasification in a High Temperature Fluidized Bed. *Canadian Journal of Chemical Engineering*. 65: 785-790.
- Utioh, A.C, N.N. Bakshi and D.G MacDonal. 1989. Pyrolysis of grain screening in a batch reactor. *Canadian Journal of Chemical Engineering*, 67: 439-442.
- Voloch, M., R. Neuman, M.R. Ladisch, R.M. Peart and G.T. Tsao. 1983. The Effects of Oxygen and Temperature on Gas Composition from Gasification of Corn Cobs. Paper presented at the 1983 winter Meeting of ASAE, Chicago, Paper No. 83-3544.

- Walawender, W.P. and L.T. Fan. 1978. Gasification of dried feedlot manure in a fluidized bed - preliminary pilot plant tests. Paper presented at the 84th National Meeting of American Institute of Chemical Engineers Journal , Atlanta, Ga, Feb. 27.
- Walawender, W.P., D.A. Hoveland and L.T. Fan. 1982. Steam gasification of Alpha- cellulose in a fluid bed reactor, presented at Fundamentals of Thermochemical Biomass Conversion Conference, Estes Park, CO.
- Walawender, W.P., S. Ganesan and L.T. Fan. 1981. Steam gasification of manure in a fluid bed: Influence of limestone as a bed additive. IGT Symposium on Energy from Biomass and Wastes V, Lake Buena Vista, FA, Jan. 26-30.
- Wander, P., C. Altafini and R. Barreto. 2004. Assessment of a small sawdust gasification unit. *Biomass and Bioenergy* 27: 467–476
- Watkinson, A., C. Cheng and C. Lim. 1987. Oxygen-steam gasification of coals in a spouted bed. *Canadian Journal of Chemical Engineers*. Vol. 65: 791-798.
- Weil, S.A., S.P. Nandi , D.V. Punwani and J.L. Johnson. 1978. Peat hydrogasification. Presented at 176th National Meeting of ACS, Maiami, Fl.
- Yin, X., C. Zhi, S. Zheng and Y. Chen. 2002. Design and operation of a CFB gasification and power generation system for rice husk Biomass and Bioenergy 23: 181 – 187.